

# NEW

**M**Motors **JSC**

Etropole - Bulgaria

# WINDOW FANS



# MM-W SERIES



MM-W are designed for continuous or timed ventilation of small and medium-size living premises, as well as sanitary and sales premises. They are mounted onto walls, window and etc.

The body is manufactured from high-quality plastic material.

An efficient shutter is provided, which prevents the inflow of cold air, when the device is not operating



The double capsulated ball-bearing of the electrical motor guarantee 30,000 hours flowless operation of the device when mounted in a horizontal or vertical position.



**LONG life 30 000h**

The IP 32 protection degree allows the ventilator to operate in high humidity and aggressive environment.

Standard for quality: The product corresponds to the international standard of quality **ISO 9001**. All components are checked up and tested at the end of the production process.

**The windows fans serial MM-W are offered in four modifications:**

1. Base model
2. With timer - circuit
3. With light relay and timer
4. With a humidity control system and timer

## base model



## with timer - circuit



The ventilator starts to operate as the switch is switched on and the built-in timer ensures operation for 5 minutes after the light is turned off.

## with light relay and timer



The ventilator starts to operate when the light is switched on and the built-in timer ensures operation for 5 minutes after the light is turned off.

# with a humidity control system and timer

The aspirator, which is equipped with a humidity indicator and a timer switches on:



**a)** when the humidity in the premises reaches over 70% the built-in timer ensures operation for 5 min. after the humidity is reduced below 70%.

**b)** manually at any time, the timer ensures operation for 5 minutes after the light is turned off and the humidity is below 70%.

The aspirator can be built with a Humidity Control System, Light Relay and Timer. In this model the Light Relay replaces the electric switch

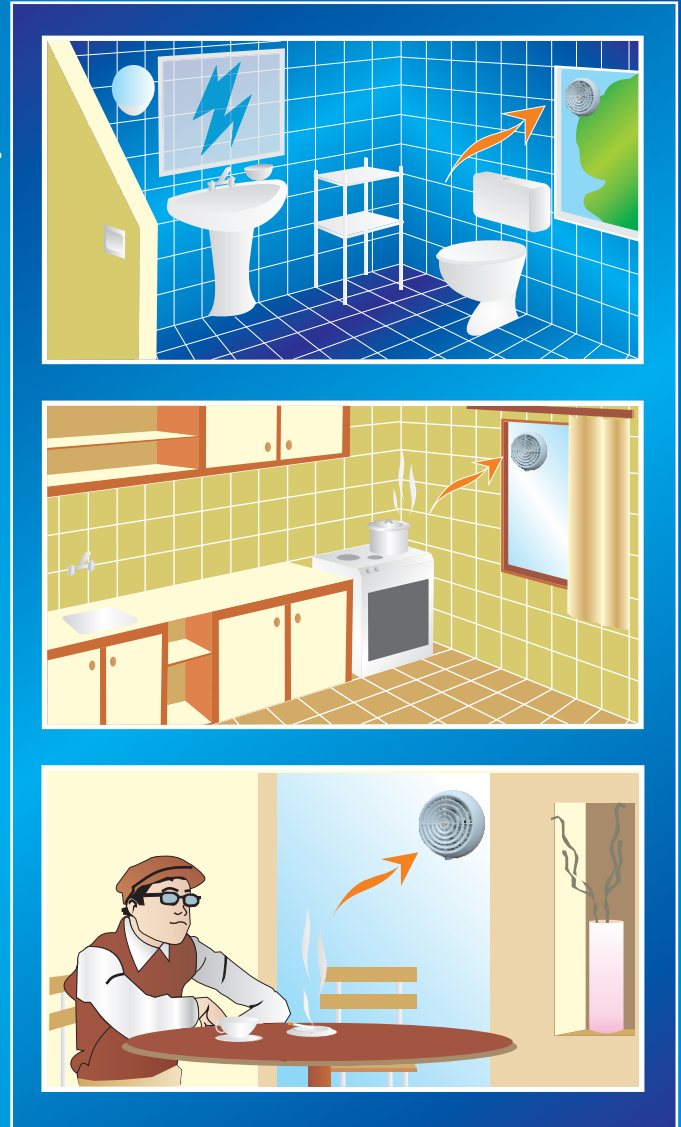

## TECHNICAL DATA

Hz/V	m <sup>3</sup> /h	W	A	min <sup>-1</sup>	IP
50/220	220:240	46	0,385	2650	32

## Scheme for mounting

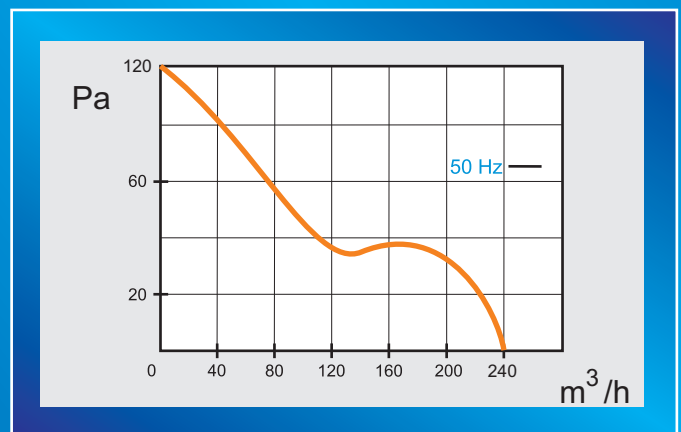
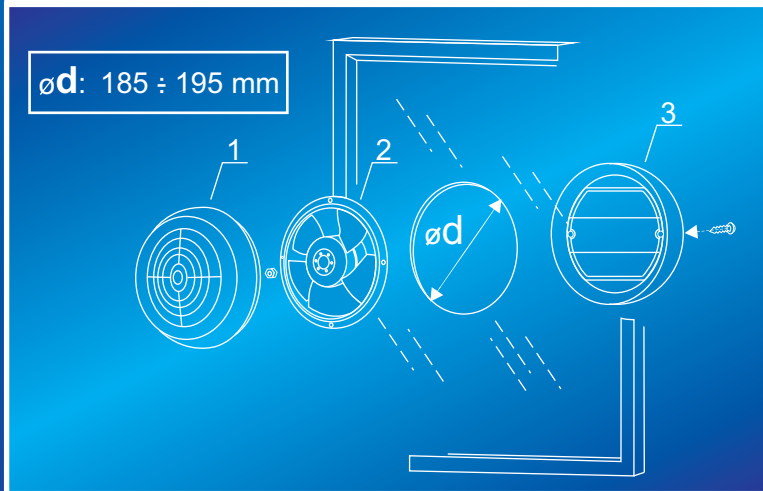

## Contacts

Factory  
3 Malak Iskar Str., 2180 Etropole - Bulgaria  
fax: (+ 359 720) 36 21

Sales:  
mobile: (+ 359 89) 9919 959,  
E-mail: laptop@mmotors-bg.com

web: [www.mmotors.bg](http://www.mmotors.bg)